



Parts List

- 1 - (A) Seat Assembly
- 1 - (B) Back Assembly
- 2 - (C) Glider Base
- 2 - (D) Bearing Arm Supports
- 2 - (E) Armrest's
- 1 - (F) Back Crosspiece (Short)
- 1 - (G) Front Crosspiece (Long)
- 1 - (H) Crosspiece Support
- 2 - (I) Lintels

Hardware

- 2 - 5/16" x 3 1/2" Stainless Wafer Bolts
- 2 - 5/16" x 2 1/2" Stainless Wafer Bolts
- 6 - 5/16" x 2" Stainless Wafer Bolts
- 12 - 3" Screws
- 8 - 2 1/2" Screws
- 28 - 2" Screws
- 4 - Lock Nuts
- 4 - Washers
- 1 - 5/32 Hex key

Tools Required

- 5/32 Hex Key (Included)
- 9/16" Wrench (Not Included)
- #2 Square Drive Bit (Not Included)

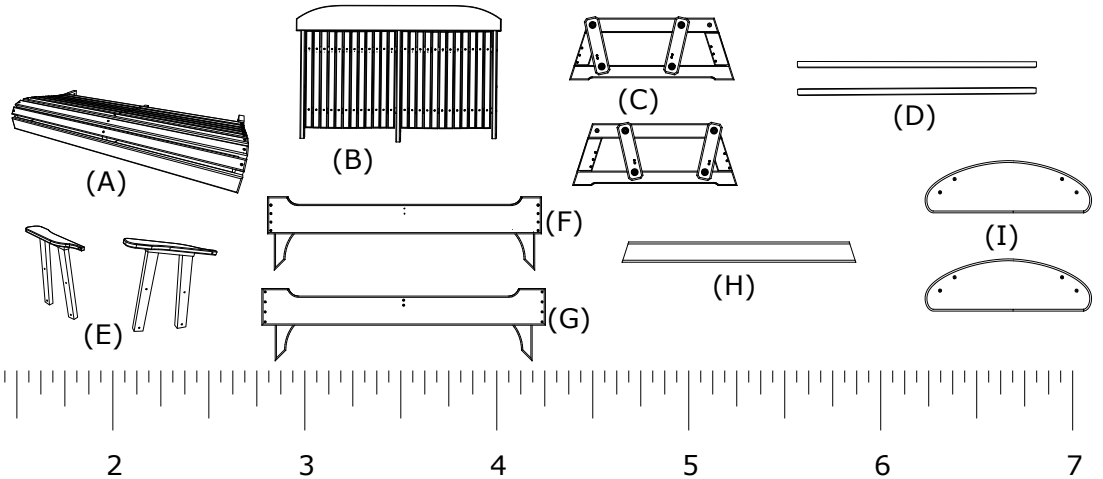

1. Attach (F) Back Crosspiece (Short) and (G) Front Crosspiece (Long) to (C) Glider Base's Using 8 - 2" and 6 - 3" Screws per side, be sure to match all numbers & or letters.

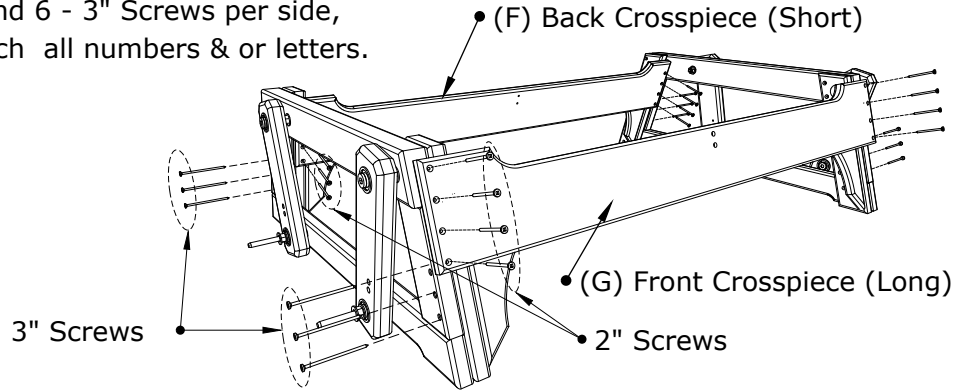

2. Attach (H) Crosspiece Support to Front-Back Crosspieces using 2 - 2" Screws per side, be sure to match all numbers & or letters.

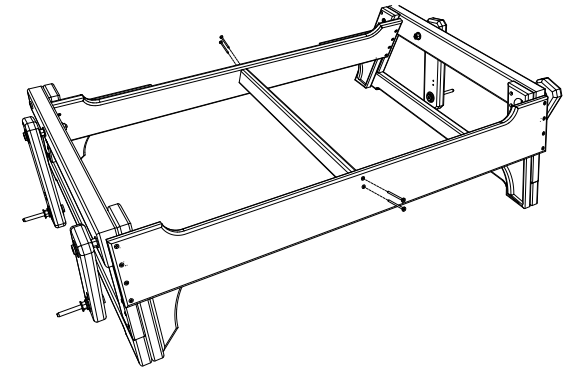

3. Attach (D) Bearing Arm Supports to Glider Base using 4 - 2 1/2" Screws per side, be sure to match all numbers & or letters.

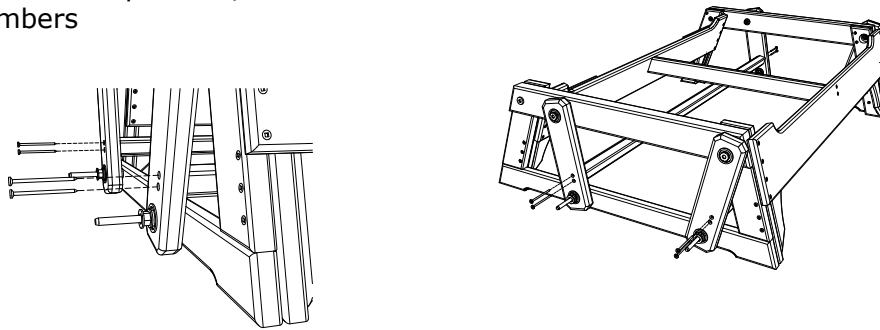

4' Classic Poly Glider Assembly Instructions

03/2/ 2020

R.M.



4. Attach (E) Armrests to Glider Base using (2-Washers)&(2-Nuts) per side, be sure to match all numbers & or letters. "Assembly order is Armrest Assembly-Washer-Nut"

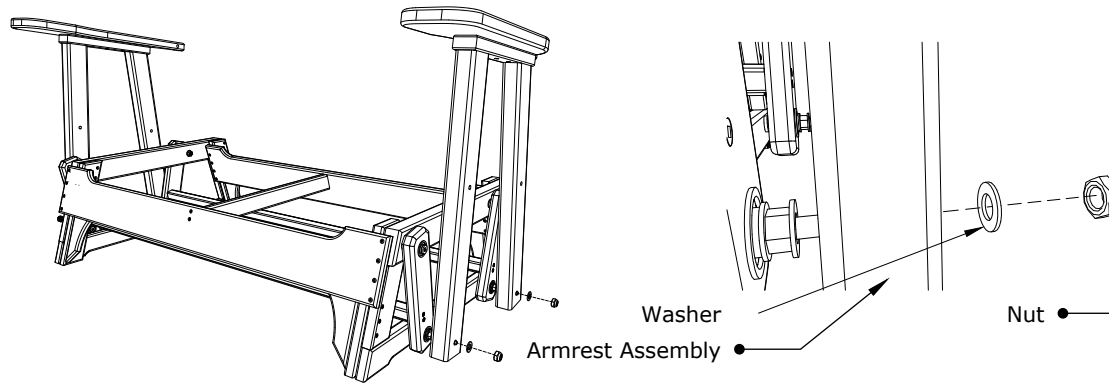

6. Attach (B)Back Assembly to (A) Seat Assembly using 4 - 2" Wafer Bolts, be sure to Match all numbers & or letters, tighten Wafer Bolts with included Hex Key.

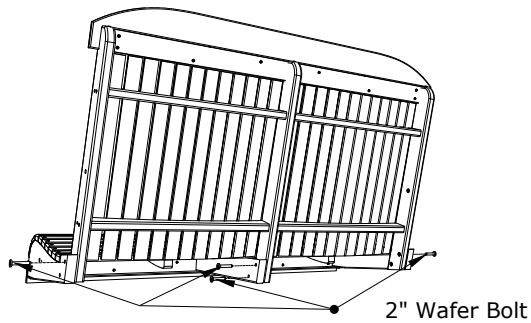

7. Attach Back-Seat Assembly to Armrests using
1 - 3 1/2" Wafer Bolt
1 - 2 1/2" Wafer Bolt &
1 - 2" Wafer Bolt
per side, be sure to match all numbers & or letters, tighten Wafer Bolts with included Hex Key.

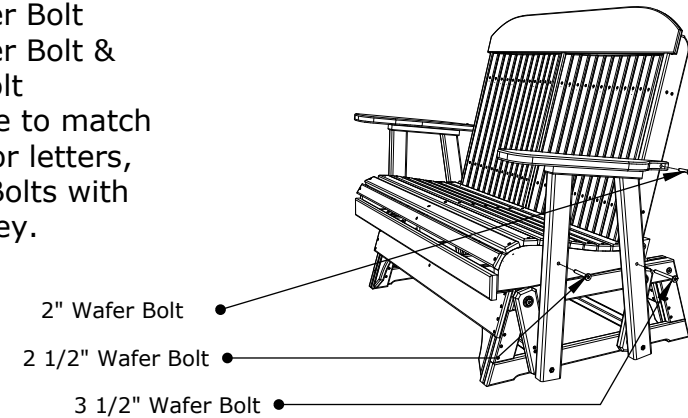

8. Attach (I) Lintels to Armrest Assemblies using 4 - 2" Screws per side, be sure to match all numbers & or letters.

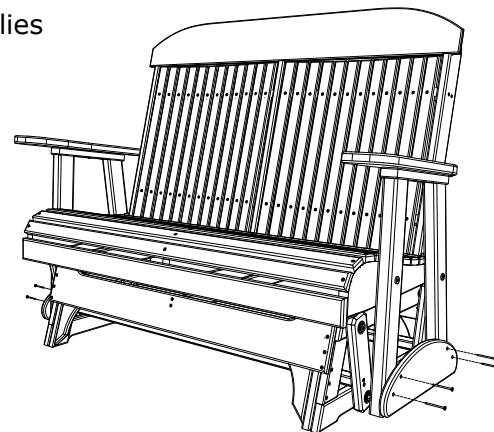

4' Classic Poly Glider Assembly Instructions

03/2/ 2020

R.M.