



Tools Required

- 5/32 Hex Key (Included)
- #2 Square Drive Bit (Not Included)

- Parts**
- 1 - (A) Seat Assembly
 - 1 - (B) Left Leg Assembly
 - 1 - (C) Right Leg Assembly
 - 1 - (D) Middle Leg Assembly
 - 1 - (E) Cross Pc.

- Hardware**
- 6 - 2 1/2" Stainless Wafer Bolts
 - 1 - 2" Stainless Steel Screw
 - 4 - 1 1/2" Stainless Steel Screws
 - 1 - 5/32" Hex Key

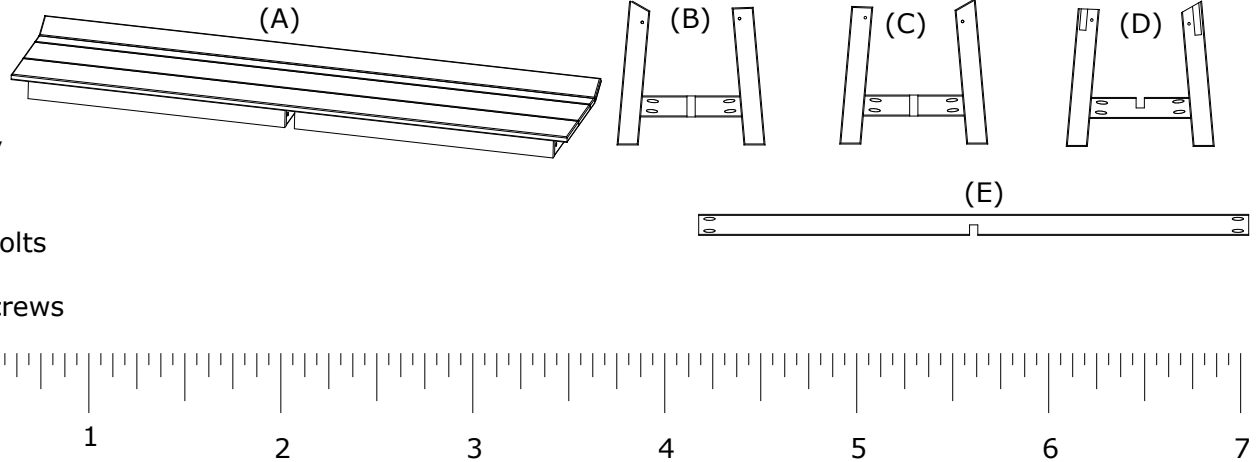

1. Attach (B) (C) & (D) Leg Assemblies to (A) Seat Assembly using 2 - 2 1/2" Wafer Bolts per Leg Assembly in predrilled holes, Be sure to match all numbers & or letters.

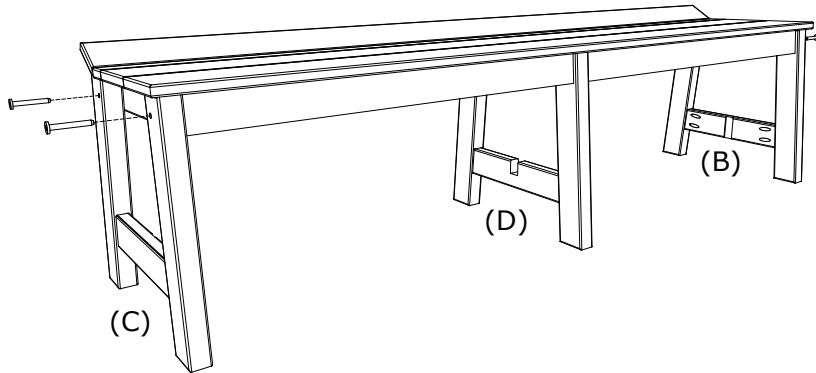

2. Attach (E) Cross Pc. to (B) (C) & (D) Leg Assemblies using 2 1 1/2" Screws per side and 1 2" Screw in center, Be sure to match all numbers & or Letters.

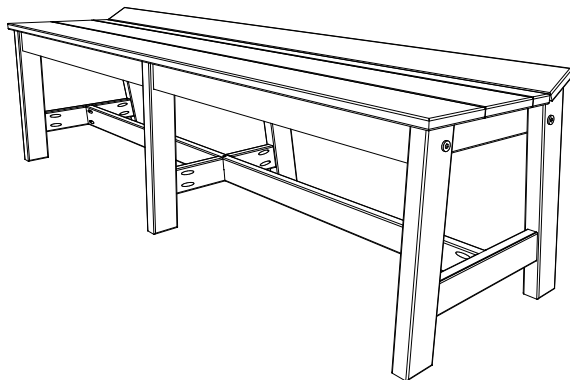
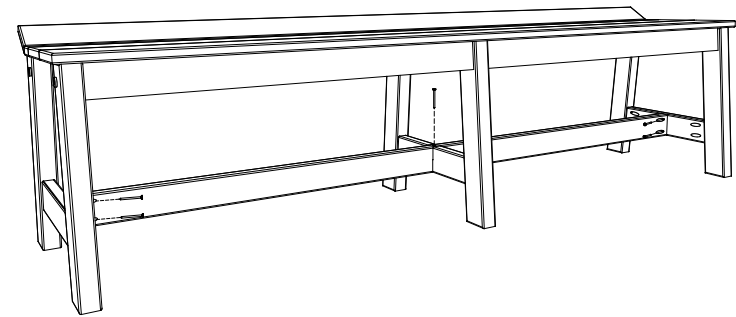

72" Café Dining Bench Assembly Instructions

12/14/ 2018

R.M.