



Tools Required
5/32 Hex Key (Included)
1/2" Wrench (Not Included)
#2 Square Drive Bit (Not Included)

Parts List

- 1 - (A) Seat Assembly
- 1 - (B) Back Assembly
- 2 - (C) Front Legs (Shortest)
- 2 - (D) Middle Legs (Longest)
- 2 - (E) Back Legs (With Wheel)
- 2 - (F) Armrest Assemblies

Hardware

- 10 - 5/16" x 3" Stainless Wafer Bolts
- 12 - 5/16" x 2 1/2" Stainless Wafer Bolts
- 2 - 5/16" Stainless Lock Nuts
- 2 - Stainless Washers
- 1 - 5/32 Hex Key

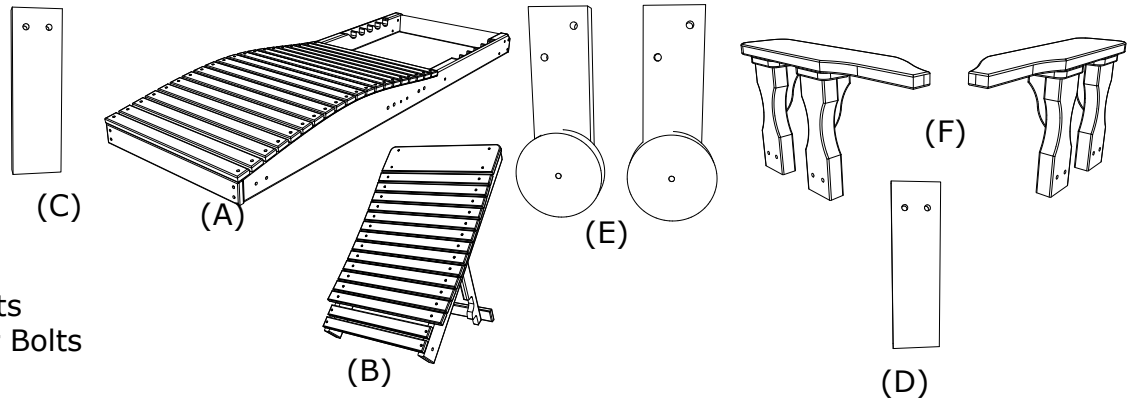

1. Attach (C) Front Legs to each side using 2 - 2 1/2" Wafer Bolts per side, Be sure to match all numbers & or letters, Tighten all Bolts with included Hex Key.

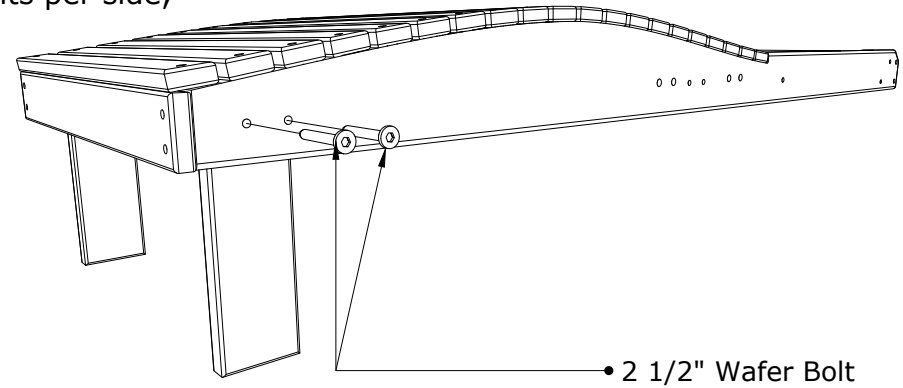

2. Attach (D) Middle Legs to each side using 2 - 2 1/2" Wafer Bolts per side, Be sure to match all numbers & or letters, Tighten all Bolts with included Hex Key.

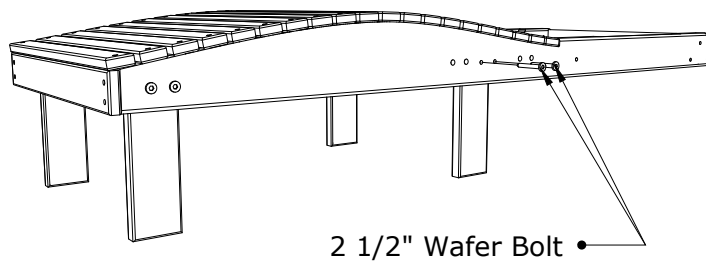

Poly Lounge Chair Assembly Instructions

10/11/ 2022

R.M.

3. Attach (E) Back Legs to each side using 2 - 2 1/2" Wafer Bolts per side, Be sure to match all numbers & or letters, Tighten all bolts with included Hex Key.

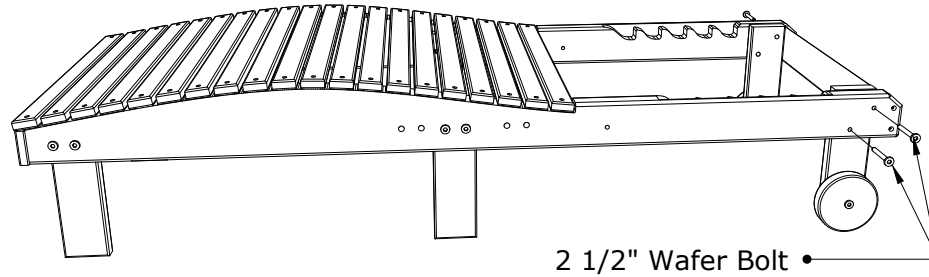

4. Attach (F) Armrest Assemblies to each side using 4 - 3" Wafer Bolts per side, Be sure to match all numbers & or letters, Tighten all Bolts with included Hex Key.

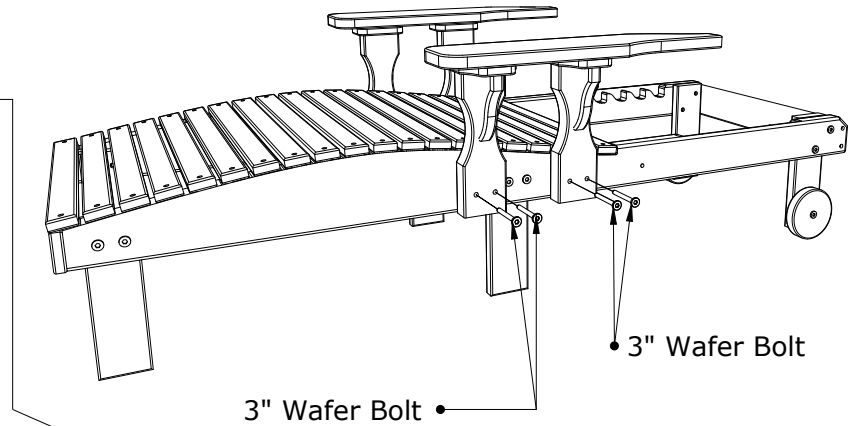

5. Attach (B) Back Assembly to (A) Seat Assembly using 1 - 3" Wafer Bolt - 1 - Washer- 1 Nut per side, Be sure to match all numbers & or letters, Tighten all Bolts with included Hex Key.

